

THIS DRAWING IS UNPUBLISHED. RELEASED FOR PUBLICATION
 © COPYRIGHT BY TYCO ELECTRONICS CORPORATION. ALL RIGHTS RESERVED.

LOC	DIST	REVISIONS					
		P	LTR	DESCRIPTION	DATE	DWN	APVD
G	14		F	REV PER ECR 07-020117	23AUG07	JR	TM

- 1 STAMP AMP 14-12, LOCATION AS SHOWN.
- 2 WIRE INSULATION DIA RANGE IS 2.0-3.2 [.080-.125] DIA
- 3 TONGUE MATERIAL THK IS 0.75±0.05 [.0295±.002]
- 4 DIMENSION APPLIES FROM CENTER OF STUD HOLE TO EDGE OF WIRE BARREL.
- 5 MATERIAL: BODY - COPPER PER ASTM B-152 SLEEVE - NYLON, COLOR WHITE
- 6 FINISH: BODY - TIN PLATE PER ASTM B-545
- 7 MAX RECOMMENDED OPERATING TEMP .105°C
- 8 VOLTAGE RATING: 300 V MAX
- 9 WIRE CROSS SECTIONAL AREA RANGE: 1.20-4.18 mm² [3,260-8,240 CMA]

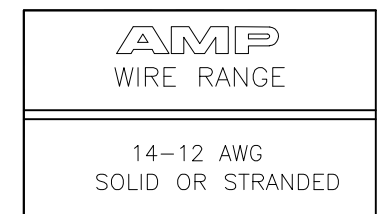
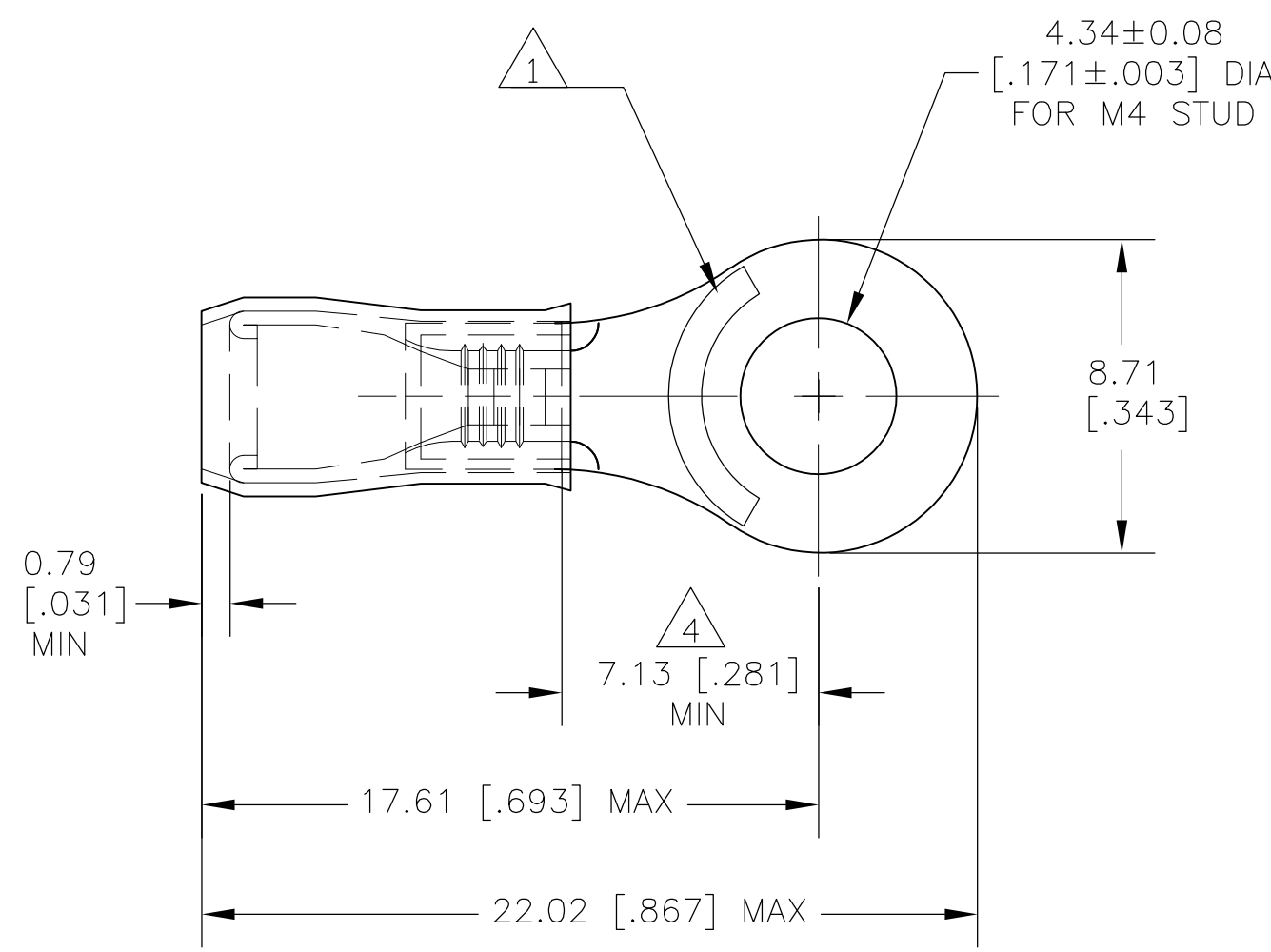

500	LOOSE PIECE	152873
QTY	PACKAGING TYPE	PART NO

THIS DRAWING IS A CONTROLLED DOCUMENT.		DWN jr_ruth 23AUG07	Tyco Electronics Corporation Harrisburg, PA 17105-3608	
DIMENSIONS: MM [INCHES]		CHK T MICHIELUTTI 23AUG07	NAME RING TONGUE, PIDG, WIRE SIZE: 14-12 AWG	
TOLERANCES UNLESS OTHERWISE SPECIFIED: 0 PLC ± - 1 PLC ± - 2 PLC ± 0.20 [.008] 3 PLC ± - 4 PLC ± - ANGLES ± 5°		APVD T MICHIELUTTI 23AUG07	PRODUCT SPEC - APPLICATION SPEC -	
MATERIAL - 5	FINISH - 6	WEIGHT -	SIZE A3	CAGE CODE 00779
CUSTOMER DRAWING			DRAWING NO G-152873	RESTRICTED TO -
SCALE 5:1			SHEET 1 OF 1	REV F